

3. Guards and safety devices

3.1 Types of guards

As outlined in Section 2.3 of this code, the OSH Regulations and the MSI Regulations contain set requirements for certain types of guards to be provided for particular cases.

The range of guards includes, but is not limited to, permanently fixed physical barriers, interlocked physical barriers, physical barriers securely fixed in position, and presence-sensing systems. Examples are outlined below.

Depending on the situation, a combination of two or more of the following guards may be required to ensure workers' safety.

3.1.1 Permanently fixed barriers (guards)

'Permanently fixed barriers' are permanently fixed physical barriers that are welded or incorporated into the body of the machine for cases in which, during normal operation, maintenance or cleaning, no person would need complete or partial access to the dangerous area.

3.1.2 Interlocked physical barriers (interlocked guards)

'Interlocked physical barriers' (interlocked guards), such as enclosure guards, are known as 'movable guards' and are interconnected with the power or control system of the machine. The interlock prevents the machinery from operating unless the guard is closed. They cannot be opened until the dangerous parts of the machine have come fully to rest.

Interconnections are usually mechanical, electrical, hydraulic or pneumatic. They provide an effective safeguard where access to the point of operation is required between each cycle of the machine or regular access is needed.

In the event of electrical failure, loss of power or malfunction, the machine's guarding system should 'fail to safe', and render the machine or part inoperable until the power is restored or the guarding mechanism is repaired.

Interlocked guards and their components must be designed so that any failure does not expose people to danger. The design also needs to consider the possibility of a person being inside the area covered by the guard when an attempt is made to start the machine.

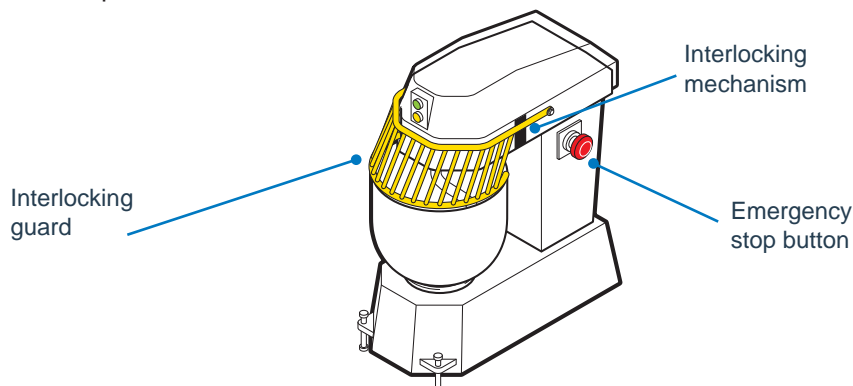

Illustration 17. Food mixer with an interlocking guard.
Yellow = guarding. Red = emergency stop button.

The type of safety device installed with the guard, and the level of integrity of the related control circuitry, can only be determined after conducting a risk assessment. If required, Australian Standard, AS 4024.1501 *Safety of machinery: Part 1501: Design of safety related parts of control systems — General principles for design* contains additional information.

If required, there is additional information in Australian Standard AS 4024, *Safety of machinery* series on types of guards and categories of reliability.

See also the WorkSafe bulletin number 5/2006, *Food preparation mixer guarding*.

3.1.3 Physical barrier securely fixed in position (fixed guards)

'Physical barriers securely fixed in position' (fixed guards) should be easy to remove and replace but only with the aid of a special tool such as a spanner, Allen key or similar tool and only when the machine is not in operation. Wing nuts, wedge inserts or similar fixing devices, which can be operated with the fingers or become stuck, should not be used.

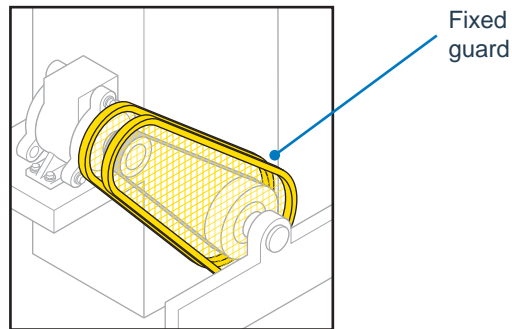

Illustration 18. Example of a fixed guard. The design of guards may have to take into account the need to adjust drive belts and transmission chains. Yellow = guarding

3.1.4 Physical barriers

Sufficient physical barriers or fences securely fixed in position by means of fasteners or other suitable devices may prevent access to dangerous areas. Any access points through the barrier, for example gates and doors, should be secured with a lock or interlocking system.

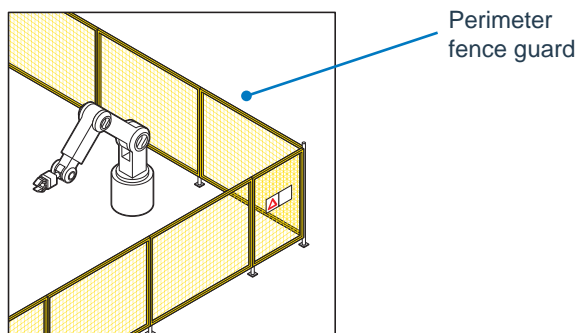

Illustration 19. Perimeter fence guard with fixed panels and interlocking access door. Yellow = guarding

With physical barriers, there is a danger of machines activating while a person is close to them, such as when an interlocked door is accidentally closed and re-activates the machine. For further information on isolation procedures, see Section 6.3 of this code.

3.1.5 Presence-sensing systems

There are two types of presence-sensing guards. These are:

- **laser guards**, which are photoelectric safety systems that detect an obstruction in the path taken by a beam or beams of light. If the field of light is broken, the machine stops and will not cycle. The invisible barrier operated by this system may consist of a single beam, multiple of beams of light, a curtain of light or any combination of these necessary to provide the required safeguard. This device should be used only on machines that can be stopped before the worker can reach the danger area; and
- **light guards**, which are light beams used in guarding of machinery. They may be a scanning beam or beams, or a number of fixed beams. The light may be visible or invisible, for example infra-red, and may be continuous or modulated.

When properly maintained, presence-sensing systems stop the machine before a person moves into a position where they could be injured, that is before access can be gained to a dangerous area surrounding the machine.

The systems can prevent a person or part of the body gaining access to a dangerous area of the machine as a result of the design, placement or junction of machine controls. They rely on sensitive trip mechanisms and the machine being able to stop quickly, which may be assisted by a brake.

Photoelectric curtains, laser scanners and pressure mats are examples of these types of guards.

Effective presence-sensing safeguard systems require selection of a trip device appropriate for the work being done, and the correct location of beams with light activated devices, taking into account speed of entry and machine stopping time.

Presence-sensing safeguard systems must be operated and maintained according to the manufacturers' instructions.

Records must be kept of any maintenance, inspection, commissioning and alteration to a presence-sensing system, as well as any test results, while it is at the workplace. These records are required to be accessible at all reasonable times to workers and, where they exist, safety and health representatives at the workplace.

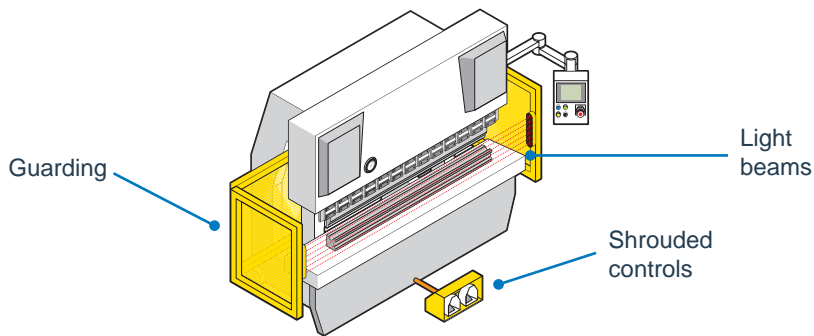

Illustration 20. Example of a photoelectric light curtain used as a trip guard. When any of the beams is blocked by intrusion towards the hazard area, the light curtain control circuit switches off the power to the hazard.

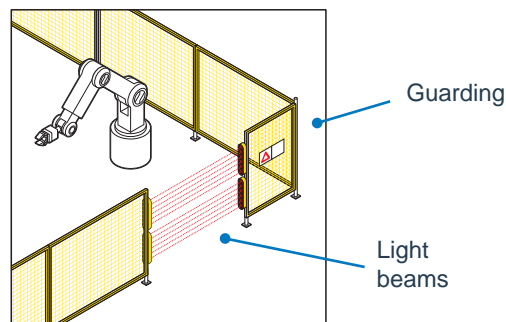

Illustration 21. Example of a photoelectric light curtain used as a trip guard. When any of the beams is blocked by intrusion towards the hazard area, the light curtain control circuit switches off the hazard power.

Yellow = guarding. Red = light beams.

Where required, see Australian Standard, AS 61508.1 *Functional safety of electrical/electronic/programmable electronic safety-related systems — General requirements* for more information in relation to safety integrity levels.

See regulation 4.34 of the OSH Regulations or, for mining industry workplaces, regulation 6.25 of the MSI Regulations.

3.1.6 Two handed controls

Two-handed control devices force the operator to use both hands to operate the machine controls. However, they only provide protection for the operator and are usually easy to defeat. They do not provide protection for anyone else who may be near the danger point.

Two-handed controls should only be used in conjunction with other guarding types and not on their own. Guards installed must be arranged to protect all people, as far as practicable.

Where two-handed controls are provided, they should be spaced well apart and/or shrouded. The machine should only operate when both controls are activated together and the control system should require resetting between each cycle of the machine.

It should not be possible to tape or weigh down one of the control buttons, nor should it be possible to operate one button with the knee, elbow, forehead or foot.

3.1.7 Combination of guards

There may often be a need for more than one type of guarding system to ensure the safe operation of machinery or plant.

Illustrated below is an example where a combination of guarding and safety devices has been used.

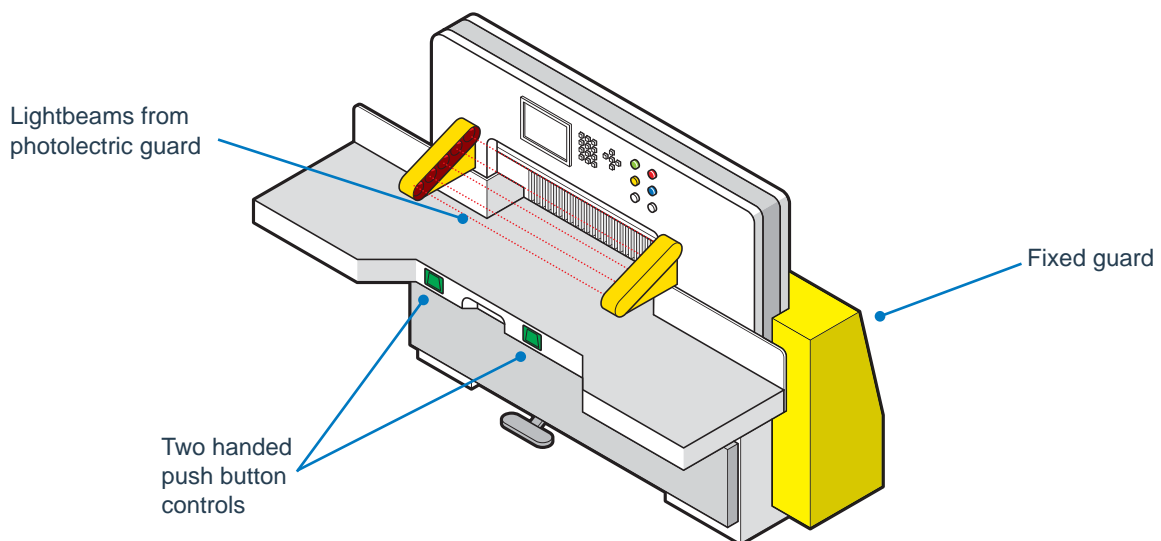

Illustration 22. Paper cutting guillotine featuring a combination of guarding and safety devices with a photoelectric guard, fixed guards and two-handed push button controls.
Yellow = guarding. Red = photoelectric guard

3.1.8 Safe system of work for unguarded areas

In cases where guarding of any moving part does not eliminate the risk of entanglement or where it is not practicable to guard it, the law requires workplaces to ensure that people do not operate or pass close to the moving part unless a safe system of work is in place to reduce the risks as far as practicable

See regulation 4.37(i) of the OSH Regulations or, for mining industry workplaces, regulation 6.27(1)(b) of the MSI Regulations.